

# Midi Traffic Light Installation Manual

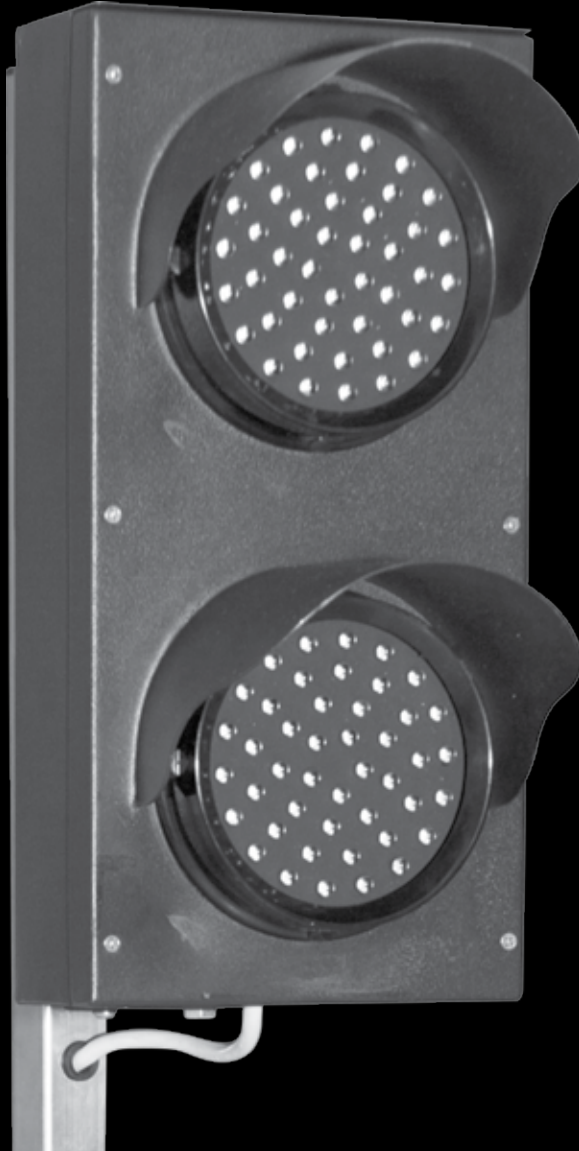

# Company Profile



1986

1990

1995

1999

Today

**In-house  
R&D  
development  
team**



**Manufacture to  
international  
quality standard  
ISO 9001:2008**



**100%  
testing of  
products**

**After-sales  
multi-language  
Technical Support  
from 07h00 to 18h00  
UTC+2  
Monday to Friday**



**Sales and technical support  
to Africa, Europe, Asia,  
the Americas, Australia  
and the Pacific**

**Centurion Systems (Pty) Ltd** reserves the right to make changes to the products described in this manual without notice and without obligation to notify any persons of any such revisions or changes. Additionally, **Centurion Systems (Pty) Ltd** makes no representations or warranties with respect to this manual. No part of this document may be copied, stored in a retrieval system or transmitted in any form or by any means electronic, mechanical, optical or photographic, without the express prior written consent of **Centurion Systems (Pty) Ltd**.



# Contents

<b>FAST TRACK</b>	Mechanical Setup	page 4
	Electrical Setup	page 5
	Commissioning and Handover	page 5
<hr/>		
<b>SAFETY FIRST</b>	<b>IMPORTANT SAFETY INSTRUCTIONS</b>	page 6
<b>1.</b>	<b>General Description</b>	page 8
<b>2.</b>	<b>Icons Used in this Manual</b>	page 9
<b>3.</b>	<b>Specifications</b>	page 10
3.1.	Physical Dimensions	page 10
3.2.	Technical Specifications	page 10
<b>4.</b>	<b>Product Identification</b>	page 11
<b>5.</b>	<b>Required Tools and Equipment</b>	page 13
<b>6.</b>	<b>Site Considerations</b>	page 14
<b>7.</b>	<b>Midi Traffic Light Installation Procedure</b>	page 15
<b>8.</b>	<b>Electrical Setup on a SECTOR Barrier</b>	page 22
8.1.	<b>Midi Traffic Light</b> - SECTOR standalone / SECTOR with CLAWS Direct Drive	page 24
8.2.	<b>Midi Traffic Light</b> - SECTOR with CLAWS Independent Drive	page 25
8.3.	<b>Midi Traffic Light</b> - CLAWS Independent Drive	page 26
<b>9.</b>	<b>Settings</b>	page 27
<b>10.</b>	<b>Electrical Setup on Other Traffic Barriers</b>	page 29
<b>11.</b>	<b>24 Month Product Warranty</b>	page 31
<b>12.</b>	<b>Installation Handover</b>	page 33

## FAST TRACK Mechanical Setup

These quick steps are for the experienced installer who needs a checklist to get a standard installation up and running in the minimum of time.

Detailed installation features and functions are referred to later in this manual.

### STEP 1

Gather Required Tools and Equipment

### STEP 2

Heed Necessary Site Considerations

### STEP 3

Mounting the Midi Traffic Light

### STEP 4

Cabling and Wiring

## Electrical Setup

### STEP 5

Midi Traffic Light Configuration

## Commissioning & Handover

### STEP 6

Carry out a Professional Handover to Client

# IMPORTANT SAFETY INSTRUCTIONS

## ATTENTION

To ensure the safety of people and possessions, it is important that you read all the following instructions.

Incorrect installation or incorrect use of the product could cause serious harm to people.



The installer, being either professional or DIY, is the last person on the site who can ensure that the system is safely installed, and that the whole system can be operated safely.

## Warnings for the Installer

**CAREFULLY READ AND FOLLOW ALL INSTRUCTIONS before beginning to install the product.**

- All installation, repair, and service work to this product must be carried out by a suitably qualified person
- Secure all easily-accessed controls in order to prevent unauthorised use of the device
- Do not in any way modify the components of the Midi Traffic Light
- Do not install the Midi Traffic Light in an explosive atmosphere: the presence of flammable gasses or fumes is a serious danger to safety
- Explain these safety instructions to all persons authorised to use the Midi Traffic Light, and be sure that they understand the hazards associated with the Midi Traffic Light
- Do not leave packing materials (plastic, polystyrene, etc.) within reach of children as such materials are potential sources of danger
- Dispose of all waste products like packing materials, etc., according to local regulations
- Neither Centurion Systems (Pty) Ltd, nor any of its subsidiaries, accepts any liability caused by improper use of the product, or for use other than that for which the product was intended
- This product was designed and built strictly for the use indicated in this documentation. Any other use, not expressly indicated here, could compromise the service life/operation of the product and/or be a source of danger
- Anything not expressly specified in these instructions is not permitted

This section has been left blank intentionally.

## 1. General Description



FIGURE 1

The **Midi Traffic Light** is an effective access control ancillary solution that enables the user to visually indicate when it is safe for a vehicle to proceed into or out of an access controlled area. While the traffic light is most often used in tandem with roadway spikes, it can be interfaced with virtually any automated system including standalone traffic barriers and even sliding gate operators.

The two output colour states, namely red and green, are displayed via a collection of superior quality LEDs that are highly visible both in bright and low-light conditions. The red output will be displayed whenever the traffic light relay is in the normally-closed state, while the green LEDs will illuminate when the relay state changes to normally-open.

The wing-shaped brackets supplied with the kit allow the traffic light to be rotated 180° in either direction.

Two configurations of the **Midi Traffic Light** are available, namely:

### Post Mount

The traffic light is fitted to the post supplied with the kit and the post is in turn fitted to a traffic barrier.

### Wall Mount

The traffic light is mounted directly to a wall or other supporting structure using the supplied wall brackets. This configuration will typically be used in applications other than traffic barrier access control.



## 2. Icons Used in this Manual



This icon indicates tips and other information that could be useful during the installation.



This icon denotes variations and other aspects that should be considered during installation.



**This icon indicates warning, caution or attention! Please take special note of critical aspects that MUST be adhered to in order to prevent injury.**

## 3. Specifications

### 3.1. Physical Dimensions

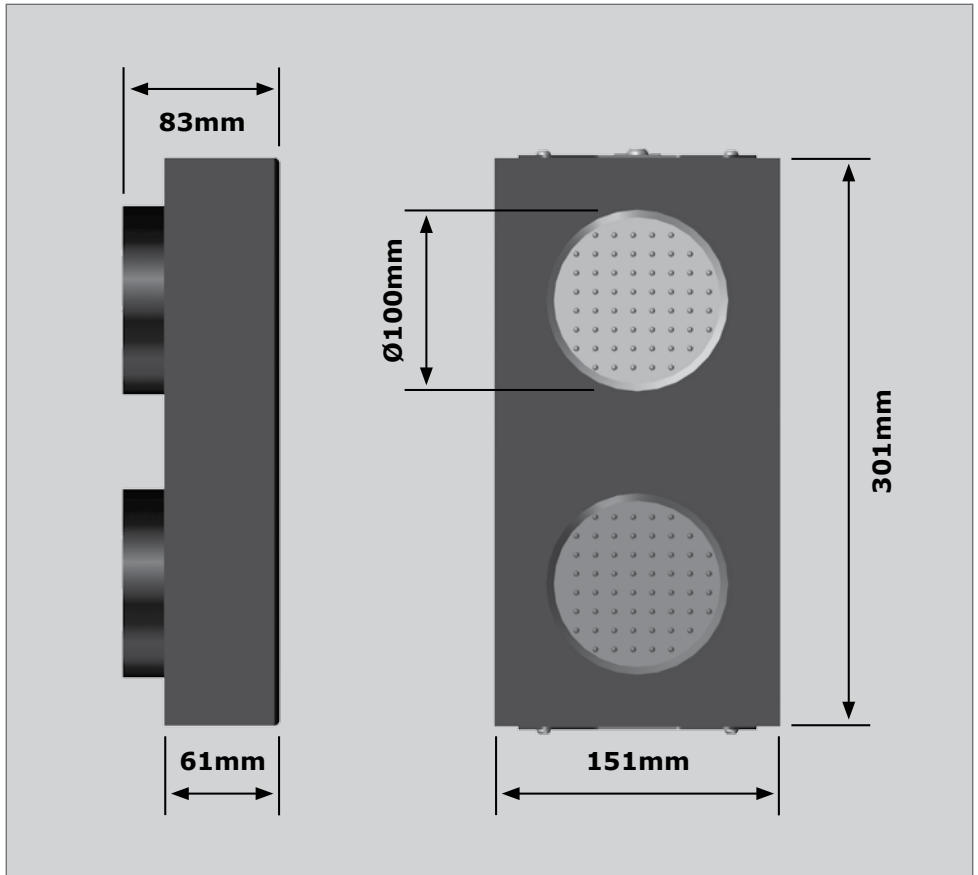

FIGURE 2. OVERALL DIMENSIONS FOR THE MIDI TRAFFIC LIGHT

### 3.2. Technical Specifications

	Midi Traffic Light	
Supply Voltage	12V - 24V DC 85V - 265V AC, 50Hz	
Colours	Red	Green
LED Qty	45pcs	45pcs
Power Consumption	≤ 6W	
Lifespan	± 50 000 hours	
Housing Material	Aluminium	

TABLE 1

## 4. Product Identification

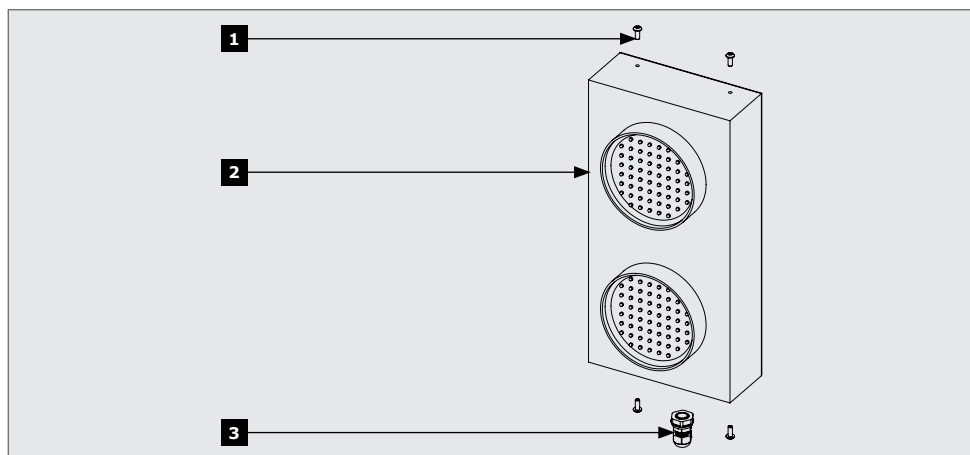

FIGURE 3A. MIDI TRAFFIC LIGHT

- 1. M4 x 8 fixing screw
- 2. Midi Traffic Light
- 3. Cable gland

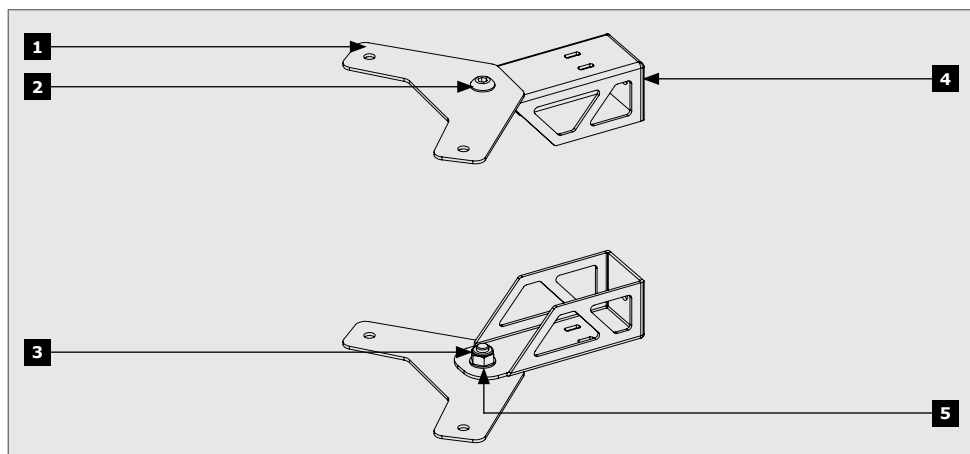
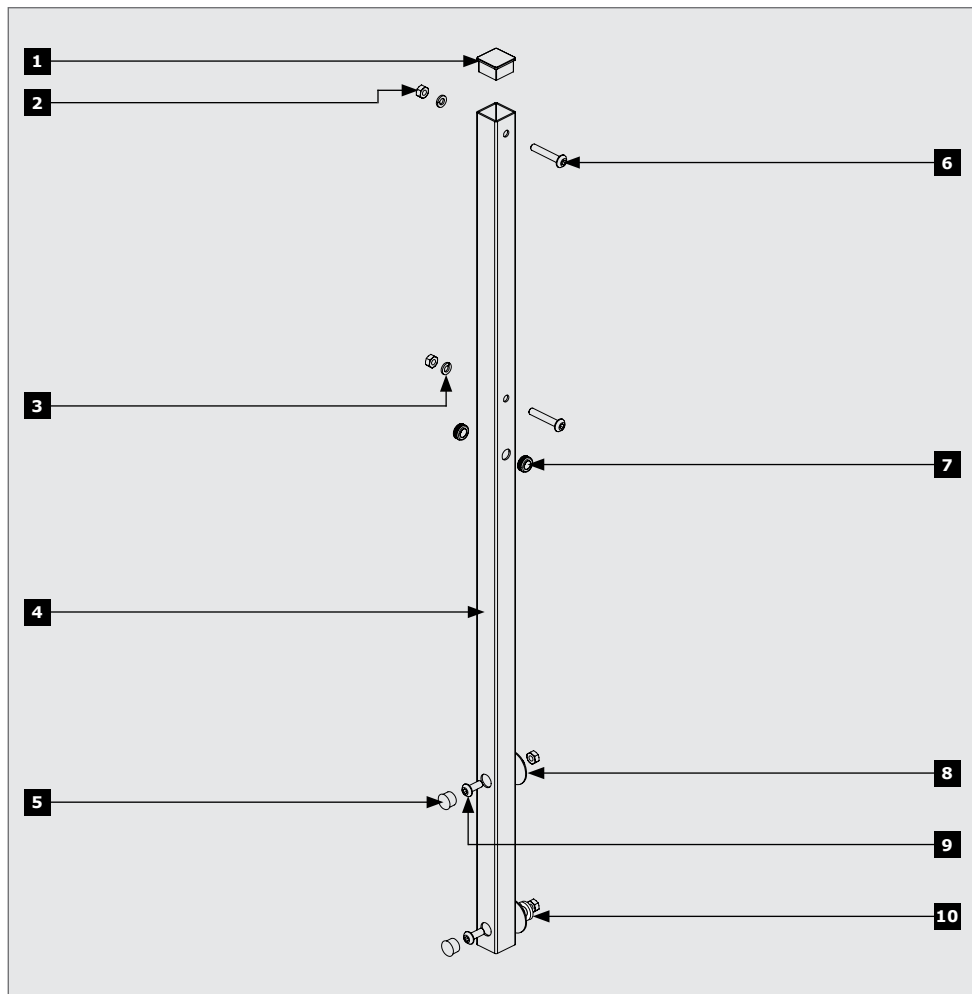

FIGURE 3B. WALL MOUNT BRACKET

- 1. Traffic Light bracket
- 2. Stainless steel hexagon socket button head M6 x 12
- 3. Stainless steel nut M6 nylock
- 4. Wall bracket
- 5. Stainless steel flat washer M6



**FIGURE 3C. PEDESTAL MOUNT BRACKET**

- |  |  |
|--|--|
| 1. Plastic end plug                                      | 7. Grommet (inside Ø7)                                   |
| 2. Stainless steel nut M6                                | 8. M6 fender washer                                      |
| 3. Stainless steel spring washer M6                      | 9. Stainless steel hexagon socket<br>button head M6 x 16 |
| 4. Upright mount post                                    | 10. Spring washer  |
| 5. Panel plug  |  |
| 6. Stainless steel hexagon socket<br>button head M6 x 35 |  |

# 5. Required Tools & Equipment

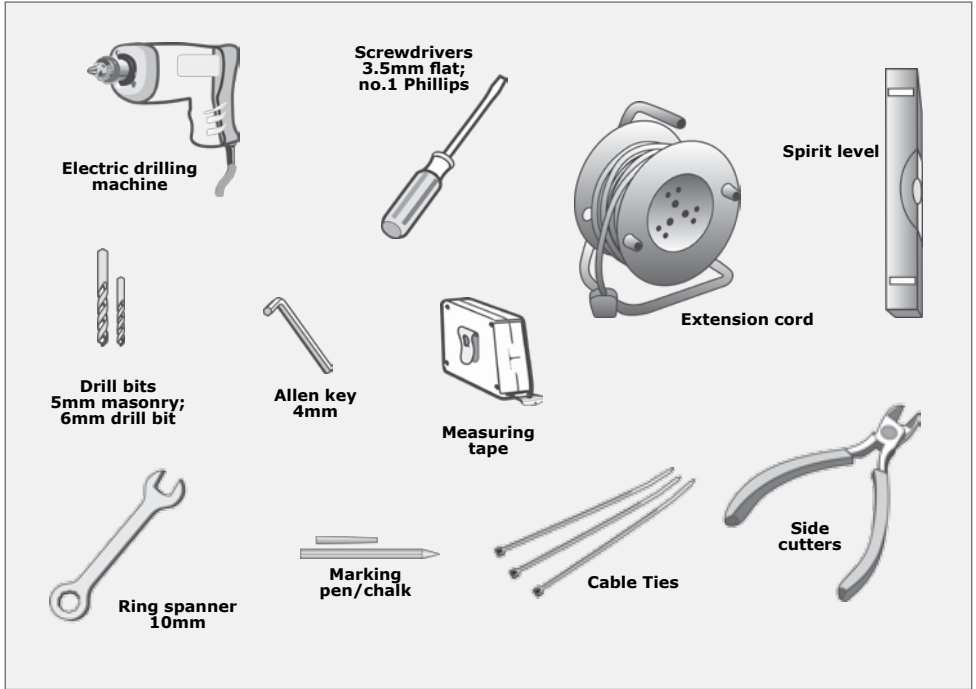

FIGURE 4. REQUIRED TOOLS & EQUIPMENT

## 6. Site Considerations

### General considerations for the installation

- The **Midi Traffic Light** must be clearly visible to oncoming traffic and nothing must obstruct the device after it has been installed
- If the installer is to drill holes in a barrier that does not provide pre-drilled holes, they must ensure that the drilling does not affect the internal electronic assembly
- There must be a minimum distance of 300mm between the top of the barrier housing and the bottom wall bracket hole
- To prevent shearing of the traffic barrier housing, ensure that big enough washers are used when securing the post to the housing
- It is also the responsibility of the installer to adequately seal the mounting holes using silicone or a similar sealant, in order to prevent the ingress of moisture, dirt and insects

## 7. Midi Traffic Light Installation Procedure



**Make sure that the mains supply to the barrier has been switched off**



**Ensure that the battery supply has been isolated by unplugging the connector on the controller**

The steps documented below must be adhered to as closely as possible in order to successfully complete the installation of the **Midi Traffic Light**.

It is important to first decide on the most suitable configuration, be it Post Mount or Wall Mount, for the site and then refer to the appropriate section in this guide.

The SECTOR traffic barrier makes provision for the fitment of the traffic light by means of two mounting holes on either side of the housing. However, the **Midi Traffic Light** can be retro-fitted onto the majority of traffic barriers, refer to the section **Post Mount – Other traffic barriers** (including older SECTOR models).

### Post Mount - SECTOR

1. Fit the two wall brackets onto the post using the two M6x35 stainless steel button head cap screws supplied with the kit. Secure the cap screws with the M6 spring washer and stainless steel nut (also provided) and tighten using a 10mm ring spanner. The wall brackets must face each other.

For aesthetic purposes, it is recommended that the cap screw is inserted from the back of the post so that the head sits unobtrusively flush with the post.

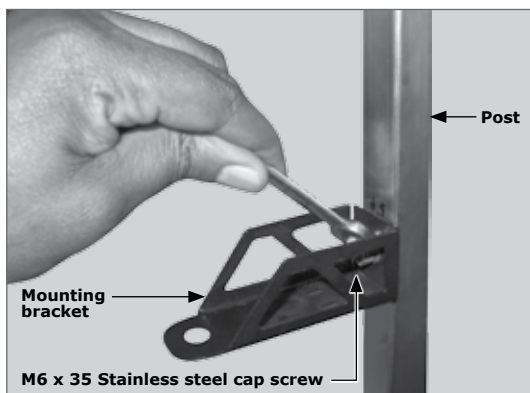

FIGURE 5

2. The two wing-shaped traffic light brackets must now be fixed to the wall brackets using the supplied M6x12 stainless steel button head screws.

For aesthetic purposes, it is recommended that the button head screw is inserted from above for the top traffic light bracket and from below for the bottom bracket.

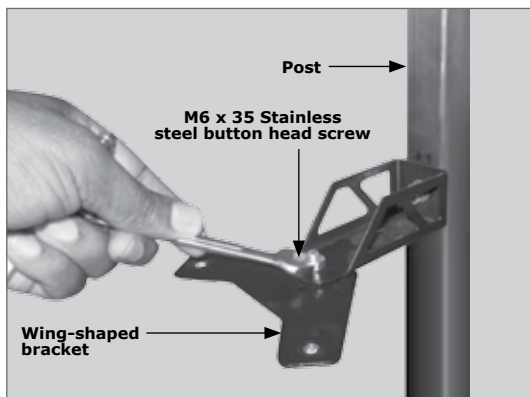

FIGURE 6

3. Fit the **Midi Traffic Light** assembly between the wing-shaped brackets and secure using the supplied M4 x 8 fixing screws.



It is recommended that the traffic light assembly is fitted last, being the heavier of the objects

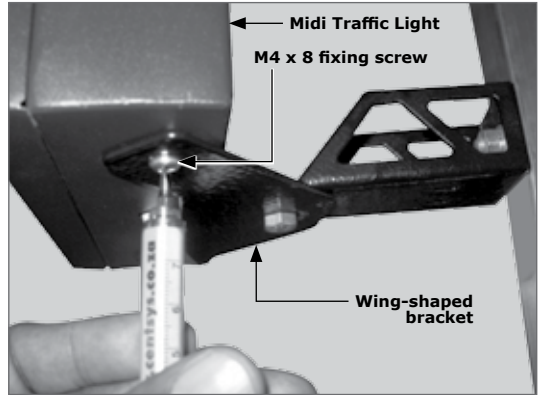

FIGURE 7

4. Route the traffic light harness through the cable entry hole and down through the post so that it protrudes from the bottom.

It is recommended that this step is completed prior to mounting the post, as the presence of the M6 cap screws used for mounting might make it difficult to route the cable.

- To facilitate easy routing of the harness through the post:
  - Remove the cable gland not being utilised i.e. the gland opposite the side on which the traffic light is fitted
  - Using a flat screwdriver, guide the cable downwards and proceed to feed it until it protrudes from the bottom of the post
  - Replace the cable gland

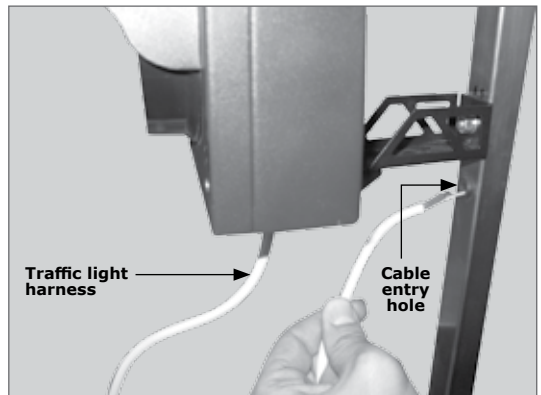

FIGURE 8

5. Decide on which side of the SECTOR the traffic light is to be mounted, and remove the two panel plugs as shown in Figure 9.

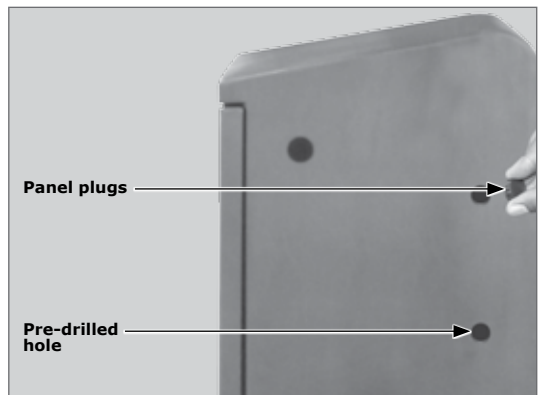

FIGURE 9



- Use the two M6 x 16 cap screws provided with the kit to fasten the pedestal to the barrier housing. Ensure that the cap screws are sufficiently tightened as failing to do so may result in the structural integrity of the enclosure being compromised.



Use the supplied fender washer, spring washer and nut in order to secure the cap screws.



It is recommended that the nut and washers are fitted on the inside of the traffic barrier housing.

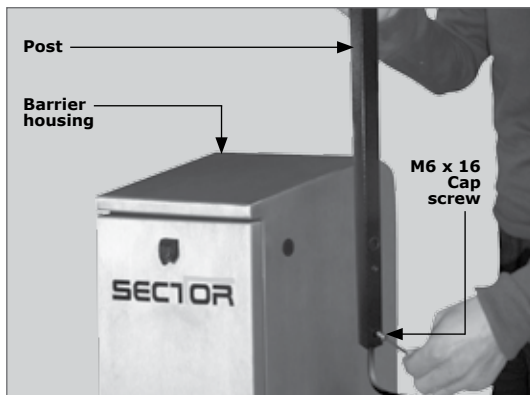

FIGURE 10

## Post Mount – Other Traffic Barriers (including older SECTOR models)

- Fit the two wall brackets onto the post using the two M6 x 35 stainless steel button head cap screws supplied with the kit. Secure the cap screws with the M6 spring washer and stainless steel nut (also provided) and tighten using a 10mm ring spanner.



For aesthetic purposes, it is recommended that the cap screw is inserted from the back of the post so that the head sits unobtrusively flush with the post.

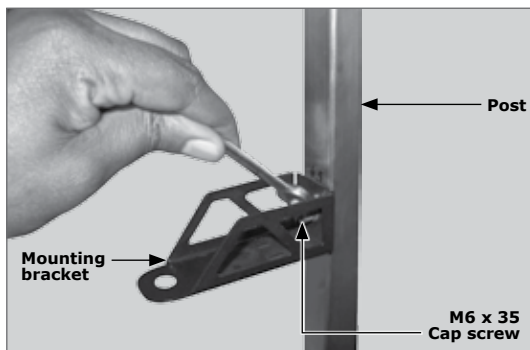

FIGURE 11

- The two wing-shaped traffic light brackets must now be fixed to the wall brackets using the supplied M6 x 12 stainless steel button head screws.



For aesthetic purposes, it is recommended that the button head screw is inserted from above for the top traffic light bracket and from below for the bottom bracket.

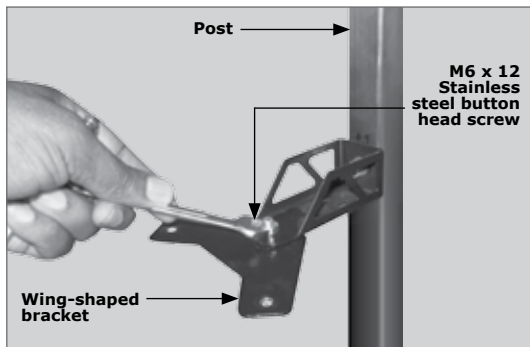

FIGURE 12

3. Fit the **Midi Traffic Light** assembly between the wing-shaped brackets and secure using the supplied M4 x 8 fixing screws.



It is recommended that the traffic light assembly is fitted last, being the heavier of the objects

4. Route the traffic light harness through the cable entry hole and down through the post so that it protrudes from the bottom as shown in Figure 14.

It is recommended that this step is completed prior to mounting the post, as the presence of the M6 cap screws used for mounting might make it difficult to route the cable.



- To facilitate easy routing of the harness through the post:
- Remove the cable gland not being utilised i.e. the gland opposite the side on which the traffic light is fitted
- Using a flat screwdriver, guide the cable downwards and proceed to feed it until it protrudes from the bottom of the post
- Replace the cable gland

5. When retro-fitting the **Midi Traffic Light** onto traffic barriers other than SECTOR, two mounting holes must be drilled in the barrier housing on the side on which the light is to be fitted.

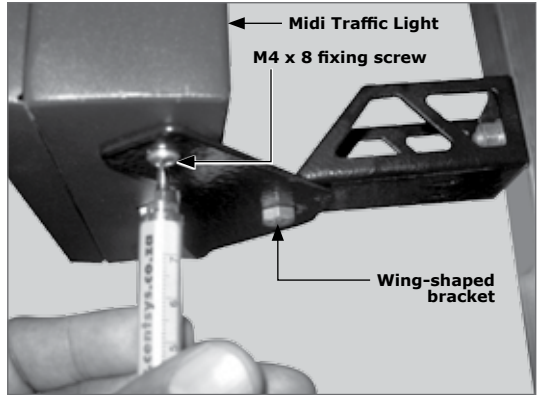

FIGURE 13

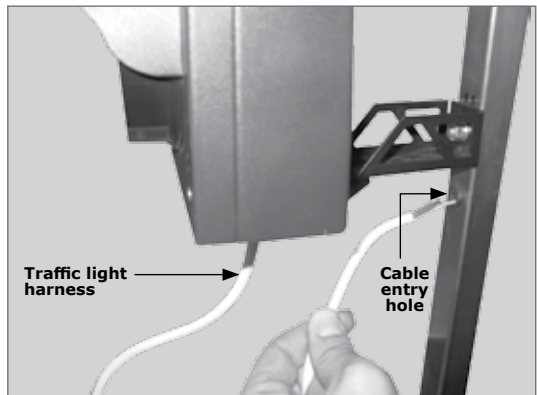

FIGURE 14

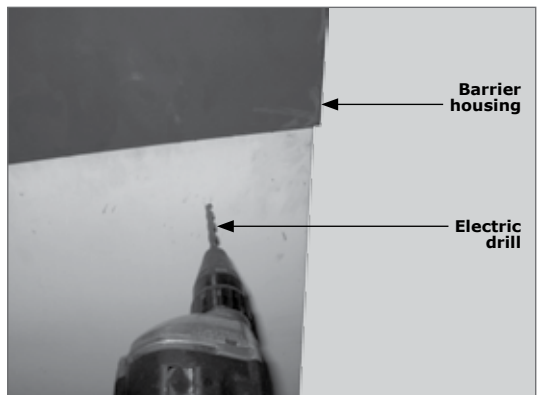

FIGURE 15

There must be a minimum distance of 300mm between the top of the barrier housing and the bottom wall bracket hole and a pitch of approximately 150mm between the two mounting holes. See Figure 16. In cases where the barrier's top cover is of such proportions that it does not allow for the holes to be drilled in the recommended locations, they can be drilled at a lower position.

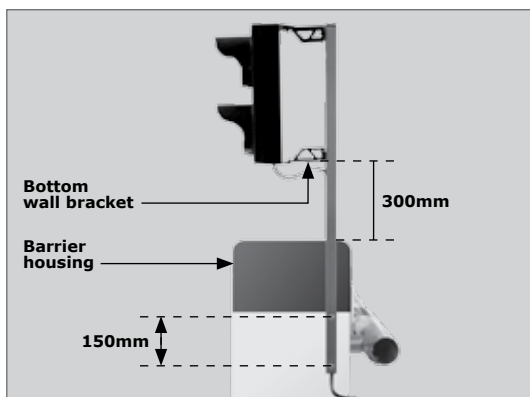

FIGURE 16

**To prevent shearing of the traffic barrier housing, ensure that big enough washers are used when securing the post to the housing. It is also the responsibility of the installer to adequately seal the mounting holes using silicone or a similar sealant, in order to prevent the ingress of moisture, dirt and insects**



- Use the two M6 x 16 cap screws provided with the kit to fasten the post to the barrier housing.

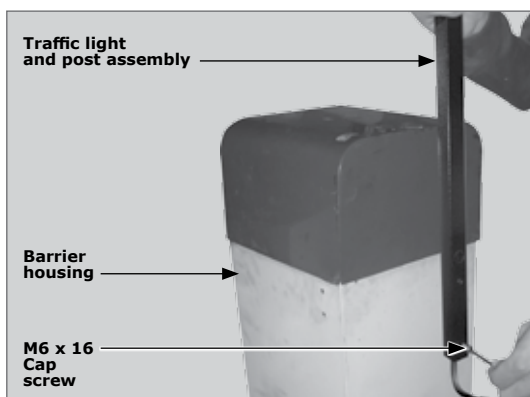

FIGURE 17

## Wall Mount

- Use the two M6 x 16 cap screws provided with the kit to fasten the post to the barrier housing.

The wall brackets must be spaced approximately 268mm apart, and the traffic light can also be used as a template to determine the position of the mounting holes.

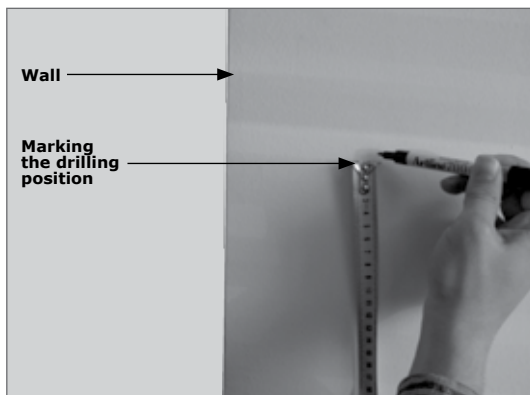

FIGURE 18

2. Drill mounting holes for the wall brackets. Note that the holes in the brackets themselves have a diameter of 6.5mm and the drilled holes as well as mounting equipment must be sized accordingly.

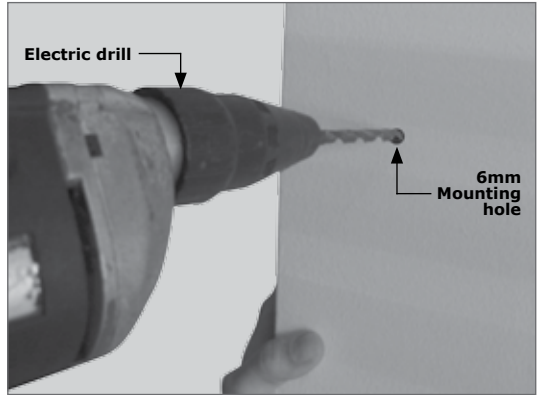

FIGURE 19

3. Mount the wall brackets using the most appropriate means.

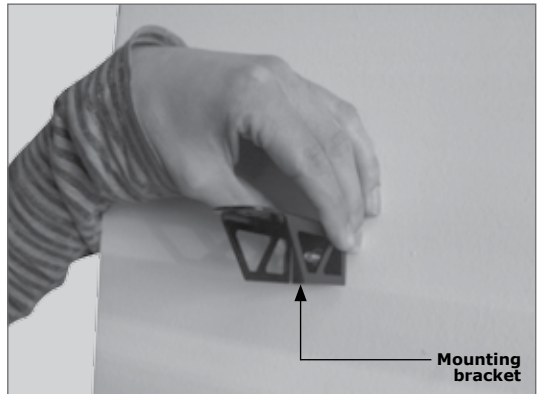

FIGURE 20

4. Fit the two wing-shaped traffic light brackets onto the wall brackets and secure using the supplied M6 x 12 stainless steel hexagon button head cap screws.



For aesthetic purposes, it is recommended that the button head screw is inserted from above for the top traffic light bracket and from below for the bottom bracket.

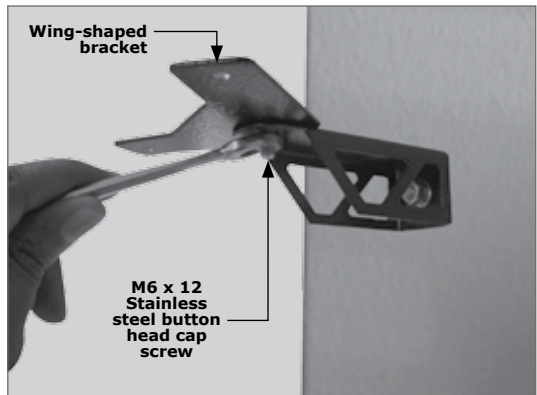

FIGURE 21

5. Fit the traffic light assembly between the wing-shaped brackets and secure using the supplied M4 x 8 fixing screws.

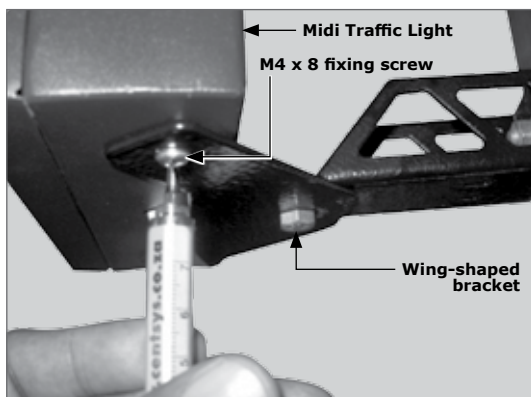

FIGURE 22

## 8. Electrical Setup on SECTOR Barrier

### Post Mount



Take care to ensure that the cable loop is well clear of the boom pole arm and/or barrier skirt as the harness could potentially get hooked while the pole is in motion and lead to the cable and/or hardware being damaged. It is recommended that the harness is tied off using a cable tie after routing.

1. Remove the panel plug located directly below the boom pole coupler to expose the cable entry hole. Typically, the entry hole closest to the side on which the traffic light is installed will be utilised.

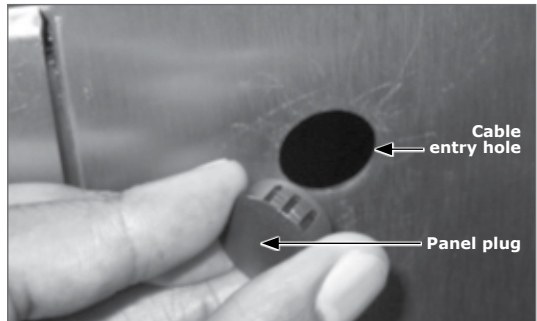

FIGURE 23

2. Fit the cable gland (supplied) into the opening as illustrated in Figure 24.

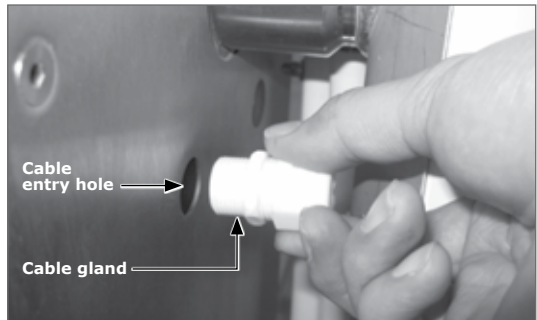

FIGURE 24

3. Feed the harness through the cable gland.

Take care to ensure that the cable loop is well clear of the boom pole arm and/or barrier skirt as the harness could potentially get hooked while the pole is in motion and lead to the cable and/or hardware being damaged. It is recommended that the harness is tied off using a cable tie after routing.

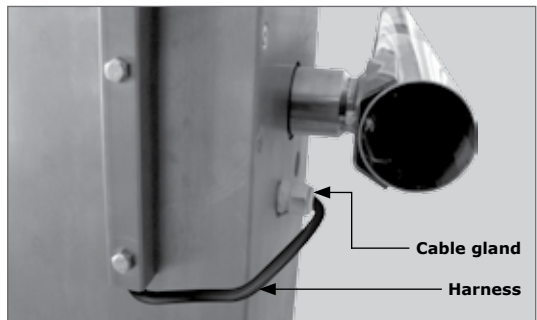

FIGURE 25

4. Tie the harness to the SECTOR gearbox using the supplied cable tie. This is to avoid the harness getting entangled in the barrier's moving parts and causing equipment damage.



FIGURE 26

## 8.1. Midi Traffic Light – SECTOR standalone/ SECTOR with CLAWS Direct Drive wiring

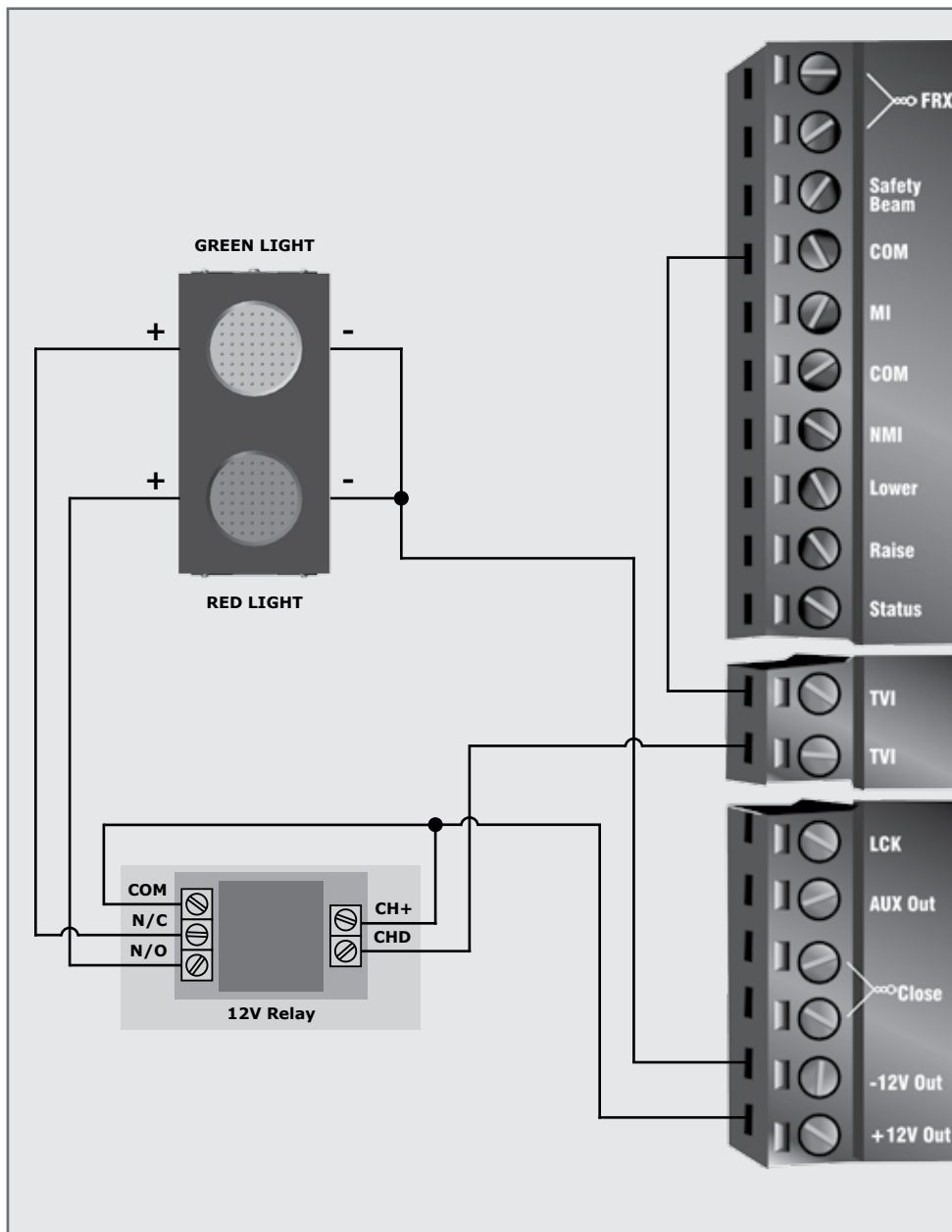

FIGURE 27





## 8.3. Midi Traffic Light – CLAWS Independent Drive Wiring

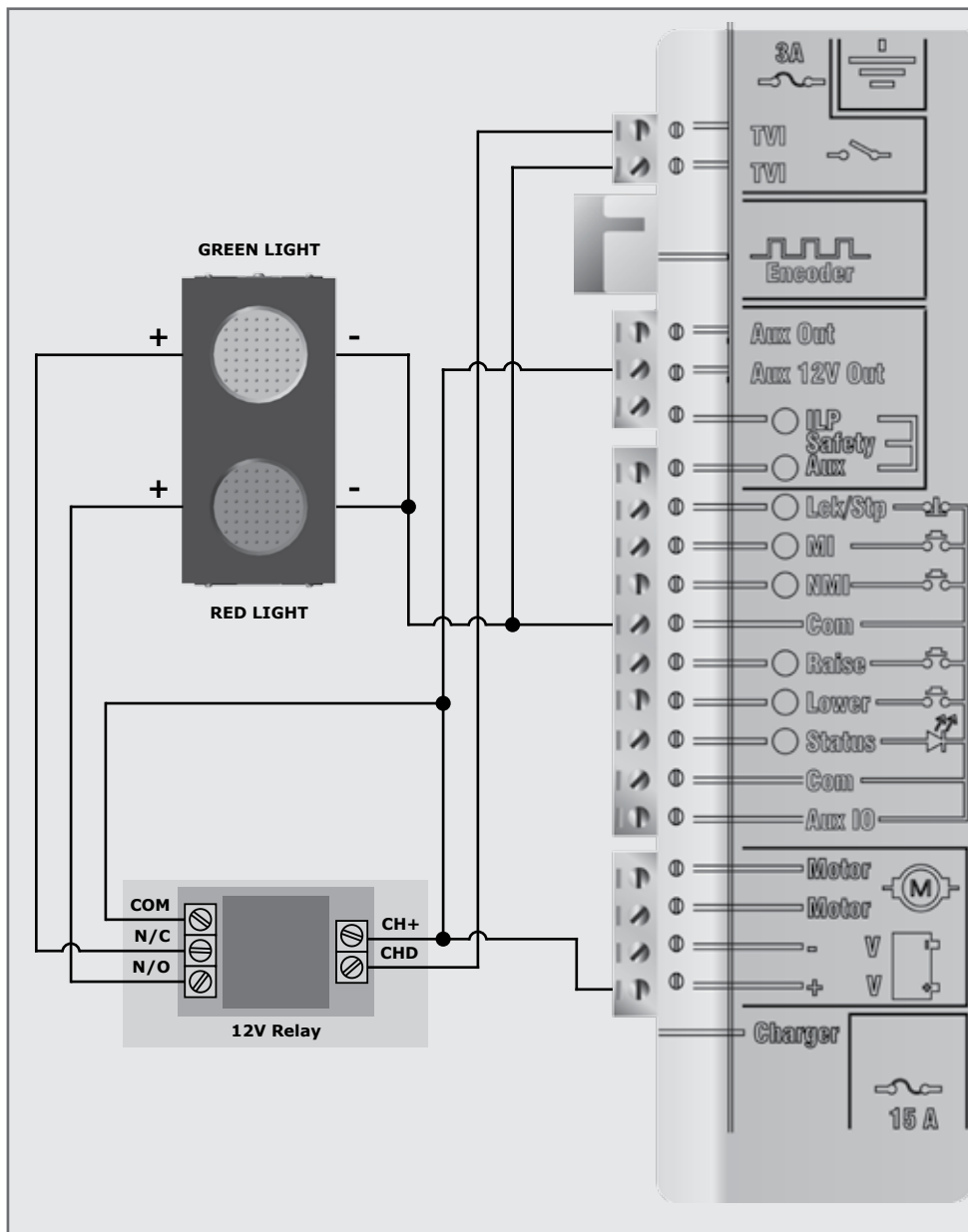

FIGURE 29

## 9. Settings

### Standalone SECTOR/SECTOR with CLAWS Direct Drive

- Access the setup menu by pressing and holding the oblong button for a period of at least two seconds
- Using the directional arrows, navigate to **Menu 7: TVI Output**
- Access this menu by momentarily pressing the oblong button
- Access submenu **7.1.: TVI Output Function**, and configure the output function as **TVI**
- Exit this submenu and navigate to submenu **7.2.: TVI Output polarity**
- Configure the polarity as **NO**
- Exit setup by pressing the round button twice

### SECTOR with CLAWS Independent Drive

#### SECTOR controller

- Access the setup menu by pressing and holding the oblong button for a period of at least two seconds
- Using the directional arrows, navigate to **Menu 4: Modes of Operation**
- Access this menu by momentarily pressing the oblong button
- Select **SPK** as the desired Mode of Operation
- Press the round button once to ascend one menu level
- Navigate to **Menu 7: TVI Output**
- Access submenu **7.1.: TVI Output Function**, and configure the output function as **TVI**
- Exit this submenu and navigate to submenu **7.2. TVI Output polarity**
- Configure the polarity as **NO**
- Exit setup by pressing the round button twice

#### CLAWS controller

- Access the setup menu by pressing and holding the oblong button for a period of at least two seconds
- Using the directional arrows, navigate to **Menu 2: Safety**
- Access this menu by momentarily pressing the oblong button
- Scroll to and enter submenu **2.5.: External Boom Status Indication**
- Scroll to and enter submenu **2.5.1.: Indicator Output**
- Set the output to **TVI**
- Scroll to and enter submenu **2.5.2.: Lowered Indication**. Set it to **ON**
- Exit this menu by momentarily pressing the round button
- Scroll to and enter **Menu 7: TVI Output**
- Configure the **TVI** Output Function (submenu 7.1.) as **TVI**
- Exit setup by pressing the round button twice

## Testing the Midi Traffic Light

Test the operation of the **Midi Traffic Light** by triggering the co-installed device(s). The traffic light should respond as follows depending on which device(s) is/are co-installed:

**Standalone SECTOR** – The red light must be permanently on while the boom pole is in the lowered position (normally-closed circuit), and change to green whenever the barrier is triggered to raise (normally-open circuit).

**CLAWS Independent Drive** – The red light must be permanently on while the spikes are raised, changing to green when they are lowered.

**SECTOR with CLAWS** - The red light must be permanently on while the boom pole is in the lowered position (normally-closed circuit) and the spikes are raised, and change to green whenever the barrier is triggered to raise (normally-open circuit) and the spikes lowered.

## 10. Electrical Setup on other barriers

### Post Mount

1. Drill a cable entry hole in the barrier housing on the side on which the **Midi Traffic Light** is installed. Refer to the supplied cable gland to get an indication of the size of the hole to be drilled.

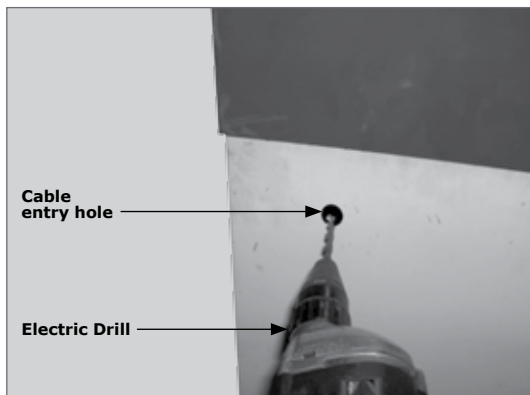

FIGURE 30

2. Fit the cable gland (supplied) into the opening.

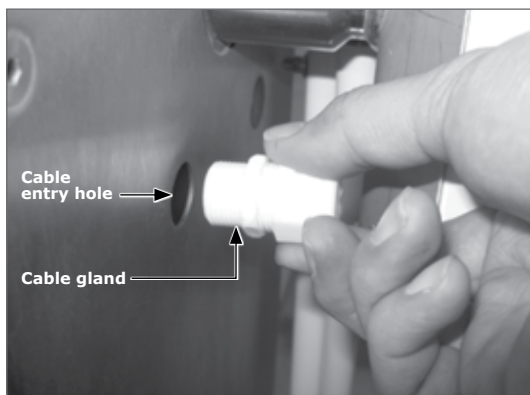

FIGURE 31

3. Feed the harness through the cable gland.

Take care to ensure that the cable loop is well clear of the boom pole arm and/or barrier skirt as the harness could potentially get hooked while the pole is in motion and lead to the cable and/or hardware being damaged. It is recommended that the harness is tied off using a cable tie after routing.

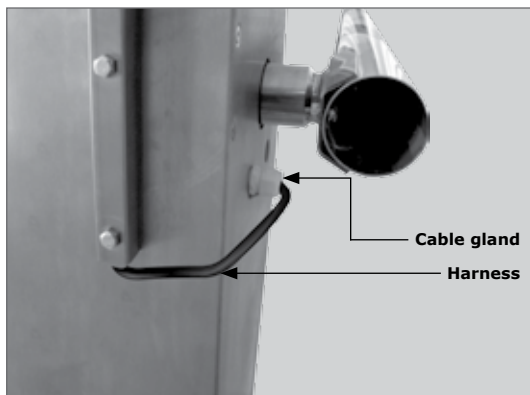

FIGURE 32

### Wall Mount

- 1. Route the **Midi Traffic Light** harness to the access control device on which it is to be used



Use cable saddles to secure the harness if it is to run along a wall, and conduit where it is to run along the ground to prevent the ingress of moisture.

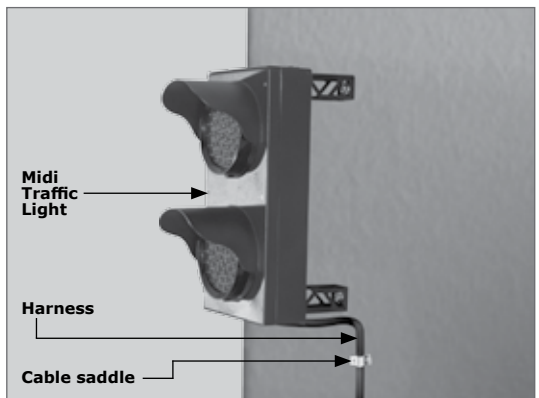

FIGURE 33

## 11. 24 Month Carry-in Product Warranty



You can register your product(s) online at [www.centsys.co.za](http://www.centsys.co.za), which will assist you in keeping a record of your date of purchase or installation, serial numbers, etc.

All of our products are manufactured with extreme care, thoroughly inspected and tested.

The goods supplied by us shall be subject to the provisions of sections 55 to 57 of the Consumer Protection Act (68/2008) except where the provisions of the warranty contained in our product documentation are more favourable to the purchaser.

Subject to the warranty contained in our product documentation, if applicable, our products are warranted for a period of twenty-four months after delivery.

However, it is expressly noted that batteries carry a six month warranty due to the nature of these products being such that they are subject to possible misuse. Please note that warranties will be honoured on a carry-in basis; in other words, the product in question must be taken in to one of our branches, or to the authorised reseller that the product was purchased from, for assessment and, if necessary, repair. For equipment not of our manufacture, the warranty as supplied by the original manufacturer will apply if such warranty is more favourable to the purchaser than the relevant provisions of the Consumer Protection Act (Act 68/2008 of South Africa), or any other applicable law as so required in different countries in which the product was sold.

Such warranty is valid only once full payment has been received for such goods.

### **Australian customers:**

Our goods come with guarantees that cannot be excluded under the Australian Consumer Law. You are entitled to a replacement or refund for a major failure and compensation for any other reasonably foreseeable loss or damage. You are also entitled to have the goods repaired or replaced if the goods fail to be of acceptable quality and the failure does not amount to a major failure

### **Any warranty may be voidable on any equipment which:**

1. Has not been installed in accordance with the installation instructions provided.
2. Has been subject to misuse or which has been used for any purpose other than that designed for by the manufacturers.
3. Has damage caused as a result of handling during transit, atmospheric conditions (including lightning), corrosion of metal parts, insect infestation, power surges or other forces outside of the control of the manufacturer.
4. Has been repaired by any workshop and / or person NOT previously authorised by the manufacturer.
5. Has been repaired with components not previously tested, passed or authorised by Centurion Systems (Pty) Ltd, South Africa or one of its subsidiary companies.

**Any warranty may be voidable on any equipment which:**

1. There has been a failure to install the product in accordance with the installation instructions provided by the manufacturer, or
2. A failure to abide by the safety instructions provided by the manufacturer, or
3. There is no breach of a legal duty of care owed to you by us or by any of our employees or agents.
4. Such loss or damage is not a reasonably foreseeable result of any such breach, and any increase in loss or damage resulting from breach by you of any term of this contract.



## 12. Installation Handover

Once the installation has been successfully completed and tested, it is important for the installer to explain the operation and safety requirements of the system.

**NEVER ASSUME THE USER KNOWS HOW TO SAFELY OPERATE THE MIDI TRAFFIC LIGHT.**

Neither Centurion Systems (Pty) Ltd, nor its subsidiaries, accepts any liability caused by improper use of the product, or for use other than that for which the product was intended.

**Ensure that the customer is in possession of the User Guide and that you have completed the installation details in the back of the User Guide.**







Connect with us on:

 [facebook.com/CenturionSystems](https://facebook.com/CenturionSystems)

 [YouTube.com/CenturionSystems](https://YouTube.com/CenturionSystems)

 [@askCenturion](https://@askCenturion)

Subscribe to the newsletter: [www.CentSys.com/Subscribe](http://www.CentSys.com/Subscribe)

**Call Centurion Systems (Pty) Ltd • South Africa  
Head Office: +27 11 699 2400**

**Call Technical Support: +27 11 699 2481  
from 07h00 to 18h00 (UTC+2)**

**E&OE Centurion Systems (Pty) Ltd reserves the right to change any product without prior notice**

All product and brand names in this document that are accompanied by the ® symbol are registered trademarks in South Africa and/or other countries, in favour of Centurion Systems (Pty) Ltd, South Africa.

The CENTURION and CENTSYS logos, all product and brand names in this document that are accompanied by the TM symbol are trademarks of Centurion Systems (Pty) Ltd, in South Africa and other territories; all rights are reserved.

We invite you to contact us for further details.



**Doc number: 0.07.D.0050\_17062015 ENG**

**[www.centsys.com](http://www.centsys.com)**