



Photon™



SAFETY BEAMS FOR AUTOMATED GATES



Head Office: +27 11 699 2400
Technical Support: +27 11 699 2481
from 07h00 to 18h00 (GMT+2)



0.07.B.0059

www.centsys.com.au

1. Introduction >>>

Photon infrared gate safety beams have been designed to provide an integral element of safety to an automated system while at the same time affording the installer considerable freedom during the installation process. The transmitter is completely wireless – being powered via two AA Alkaline batteries – obviating the need for tunnelling and digging and subsequent defacement of one's driveway for the purpose of running cables. Not only does this arrangement allow for significant flexibility and fewer restrictions when it comes to mounting the beams, but it dramatically reduces material and labour costs.

2. Safety Instructions >>>



- All installation, repair, and service work to this product must be done by a suitably qualified person.
- Do not in any way modify the components of the system.
- Do not leave packing materials (plastic, polystyrene, etc.) within reach of children as such materials are potential sources of danger.
- Dispose of all waste products like packaging materials, according to local regulations.
- CENTSYS does not accept any liability caused by improper use of the product, or for use other than that for which the automated system was intended.
- This product was designed and built strictly for the use indicated in this documentation. Any other use, not expressly indicated here, could compromise the service life/operation of the product and/or be a source of danger.
- Anything not expressly specified in these instructions is not permitted.

3. Icons used in this guide >>>



This icon denotes variations and other aspects that should be considered during installation



This icon indicates warning, caution or attention! Please take special note of critical aspects that MUST be adhered to in order to prevent injury

4. Operation >>>

When connected to an automated system such as a gate motor or garage door operator, the Photon beams aid in preventing personal injury, and/or property damage due to crushing, when used in a closing beam configuration. When used in an opening beam configuration, the Photon beams dramatically reduce the hazardous actions associated with a gate that is opening; such as dragging or shearing. The operation of the Photon beams relies upon the infrared beam being interrupted by a person or object, and notifying a device connected to its fail-safe contact, of the interruption.

In addition, Photon beams are compatible with the unique Intruder-detection alarm functionality inherent in some of CENTSYS's gate operators. These operators allow the Photon beams to act as sophisticated perimeter security device by activating an alarm on the operator's controller, or a third-party alarm system, whenever the beams have been obstructed or remain obstructed for a predefined period of time*

* Refer to the relevant product documentation for further information on Intruder-detection Alarm functionality.

5. Technical specifications >>>

Power supply	Transmitter: 2 x AA Alkaline Batteries (Supplied)* Receiver: 12 – 24V AC 12 – 30V DC
Power consumption	Receiver 30mA @ 12V DC (Relay) 15mA @ 12V DC (Open Collector)
Transmitter battery life	Minimum 2 years
Battery low indication	Audible Beep
Maximum operating distance	10m
Alignment	Automatic – 1m ² @ 10m**
Output contact	Fail safe, N/C and N/O potential free / N/C Open Collector***
Output contact rating	3A @ 30V DC Non-inductive/ 50mA @ 30V DC (Open Collector)
Operating temperature	-15°C – +65°C
Operating humidity	0 – 90% Non-condensing
Housing material	ABS
Degree of protection	IP54

* Only replace with alkaline batteries. Do not use rechargeable batteries with this product.
** Circular Area – Assuming a parallel surface.
*** Selectable by jumper

6. Installation >>>

The transmitter has been fitted with a "power up" jumper. In order to preserve battery life, the unit has been packed with the jumper in the OFF position; to power up the transmitter, simply position the jumper so that it is bridging the ON and COMMON pins as illustrated

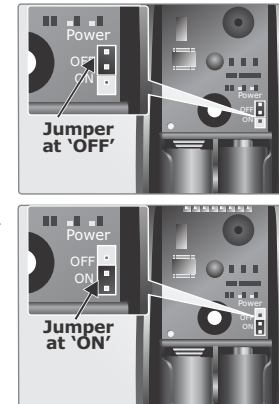

Installer Mode

Installer Mode is a unique feature that facilitates the alignment of the beams by providing audible feedback via the receiver's onboard buzzer.

- To enter Installer Mode, press and hold the pushbutton on the receiver for a period of 1 second. The buzzer will emit two beeps to indicate the transition into Installer Mode
- Once in Installer Mode, the LED will illuminate permanently, while the IR beam signal is not being received by the receiver.
- Next, proceed with the alignment of the beams noting the behaviour of the receiver; as soon as the beams are suitably aligned, the LED will switch off and the buzzer will emit a continuous 4KHz tone.
- The transmitter will remain in Installer Mode for a period of 120 seconds, but an early exit can be invoked by momentarily pressing the pushbutton.

Beam alignment

- The first step when installing the Photon infrared beams is to obtain maximum alignment.



The beam lenses MUST be fitted during the alignment procedure as they serve to focus the infrared beam. Failure to do so may result in an inability to achieve alignment.

- The transmitter and receiver are typically mounted directly opposite one another, but some leeway is given in the form of a wide beam being cast should absolute alignment not be possible
- It is of paramount importance that the beams are mounted on surfaces that are reasonably parallel to one another. Small differences in the angle between the opposing parallel surfaces, can lead to large offsets between the transmitter and the receiver alignment of the beams - the greater the distance the infrared beam travels between the transmitter and the receiver, the larger the offset
- For ease of alignment, an onboard buzzer has been provided on the receiver, that can be activated by placing the Photon receiver unit in Installer Mode, described in the relevant section

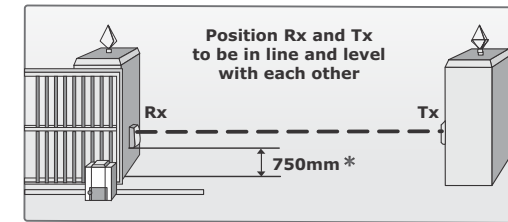

CENTURION recommends the height of 750mm, but the height of the beam must be tailored to suit the specific requirements of the installation

Remove cover and prepare for mounting

- Unclip screw-hole cover piece.
- Unscrew cover retaining fastener.

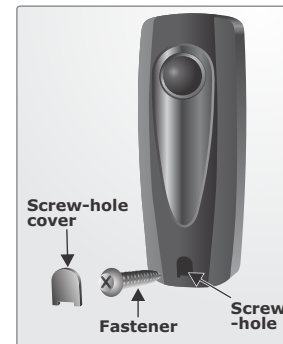

- Lift off cover as shown in the illustration.



There is no need to remove the PCB when mounting the Photon. The mounting hole is easily accessible making mounting quick and easy

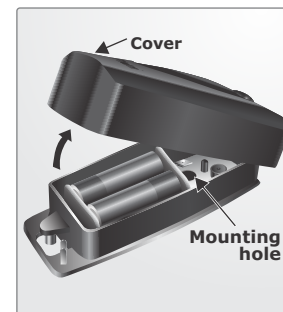

Mounting

- Mark position of receiver unit.
- Use 5mm masonry bit to drill hole in wall.
- Mount using fastener provided.
- Repeat the same mounting procedure when mounting the transmitter unit.

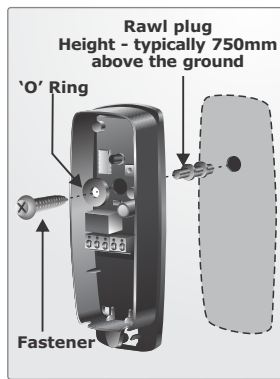

Wiring route

- Break out the relevant knockouts and route the cables through the cable cut-out as shown in the illustration, providing 12V - 24V AC or 12V - 30V DC to the receiver.

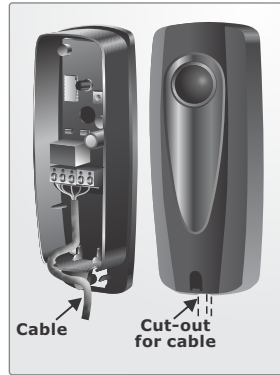

PCB connections

Receiver

- The receiver's relay can then be connected to the input of an external device using either the normally-open or normally-closed contact shown in the wiring diagram.

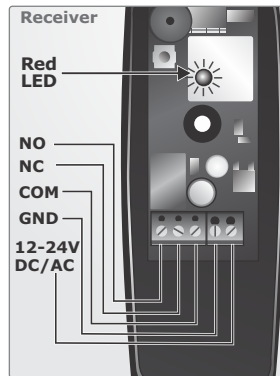

- Test the operation of the **Photon** infrared beams by passing an object such as your hand through the beam; there should be an audible 'click' to indicate that the internal relay is being de-energised. If the beams have been connected to an automated system, the operator should immediately halt movement when the beams are obstructed.

⚠ If Open Collector is used, there will not be a "click"

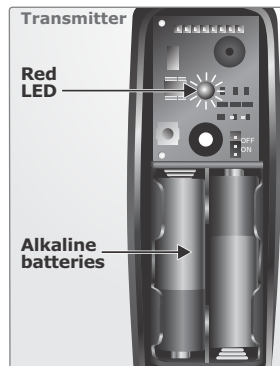

Double wireless closing safety beams connection to D-Series controller

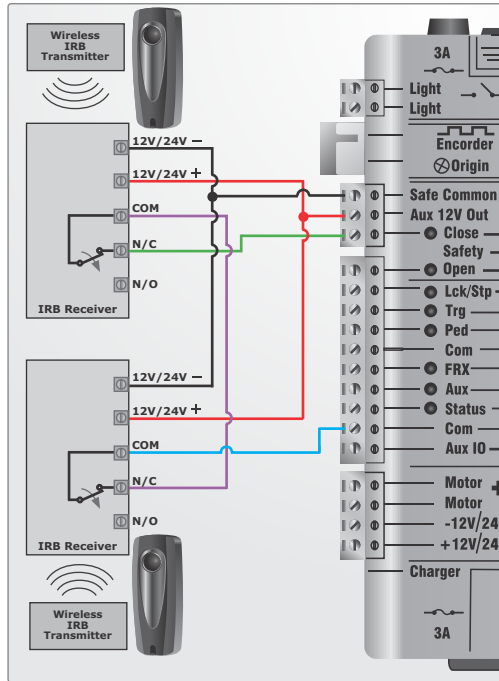

Open Collector Mode

In sites where current consumption is a factor, for e.g. solar-powered installations, the onboard relay can be disabled by selecting Open Collector Mode. This is accomplished by moving the jumper on the receiver from pins 2 and 3 to pins 1 and 2. The open collector output is then available on the normally-closed terminal, and will switch down to ground.

Indicators

The receiver has been fitted with a **red** LED for feedback and diagnostic purposes.

- The **red** LED will flash five times on power-up, to indicate the unit is powering up correctly.
- In Normal Mode of Operation, the **red** LED will flash briefly, once every second, while the IR beam signal is not detected (i.e. While the IR beam is obstructed).
- In Installer Mode, the **red** LED will remain on, while the IR beam signal is not detected (i.e. While the IR beam is obstructed).
- The **red** LED will remain off in both modes, if the beam signal is detected

In addition, both the receiver and transmitter modules have been fitted with onboard buzzers, which provide the following feedback:

- The buzzer on the transmitter PCB will emit an alarm tone when the batteries are nearing the end of their functional life. Should the user not have replacement batteries at his disposal at the time of notification, the buzzer can be disabled for a period of 24 hours by momentarily pressing the pushbutton
- The receiver buzzer will emit a continuous 4KHz tone when alignment is obtained **ONLY** if Installer Mode is enabled.

Wireless opening safety beams connection to D-Series controller

